



View / Back View

Vehicle Camera



Mobile Surveillance

NEW 2012 FEB. V1.0



1/3" CCD



LENS
4 mm



0.1
Lux



520TVL



DC 12V



66°



MIRROR
optional

AVM-950H AVM-950H-BV (Back View)

- 1/3" CCD
- High Horizontal Resolution Max. 520 TV Lines
- Lens Mount: 4mm
- The camera is not waterproof. Indoor Installation Only.
- For Back-draft • Mirroring. (AVM-950H-BV)



AVM-950H / AVM-950H-BV

View / Back View Vehicle Camera

SPECIFICATIONS

Mode	NTSC	PAL
Pick Up Element	1/3 Inch CCD Image Sensor	
Image Signal Process	Digital Signal Processing System	
Number Of Pixel	768 (H) × 494 (V)	752 (H) × 582 (V)
Picture Elements	Approximately 380K	Approximately 440K
Horizontal Resolution	Approximately 520 TV Lines	
Power Supply	DC 12 ± 1V	
Current Consumption	80 mA	
Synchronization	Internal	
Scanning System	2 : 1 Interlace	
Sensitivity	0.1 LUX	
S/n Ratio	Max 48 dB	
Auto Electronic Iris	Automatically	
Back Light Compensation	YES	
Auto Gain Control	Automatically	
Electronic Shutter	NTSC: AUTO: 1/60S TO 1/100,000 S PAL: AUTO: 1/50 S TO 1/100,000 S	
Output	1 Vp-p Composite Video Output, 75 Ohms	
Lens Mount	4mm LENS	
Operating Temperature	- 10° C ~ + 60° C	
Weight	About 50g	

*Version updating is not going to inform, please check the on-going updating information

Classification	Appropriate Vehicle Types
 S-TYPE	 Suitable for slanting wind shield of vehicles, eg. Taxi cab, Police car, Van, Sedan, MPV, SUV, SUT, Recreation Vehicle
 L-TYPE	 Suitable for upright wind shield of vehicles, eg. Truck, Bus, Pickup, Trailer

Installation

Front windshield



Back windshield

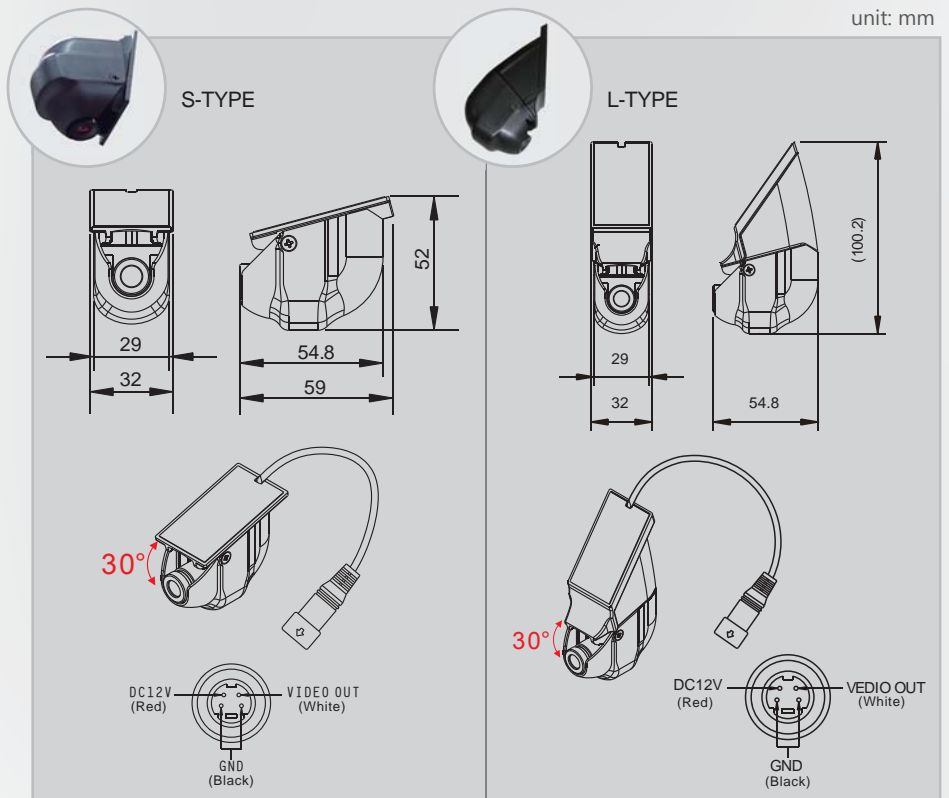

■ DISTRIBUTED BY

TIPRONET
mobile logistic location