

# FUHO Vandalproof 3-Axis Dome Color Camera

## VP-326 / VP-326H

Vandal Dome Camera High Resolution

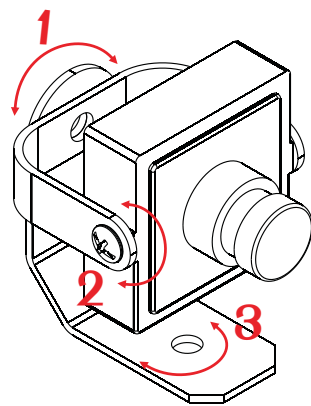

### Features

- 1/3" SONY CCD
- Low light sensitivity of 0.01Lux.
- Vandal-Resistant case design.
- 3-Axis camera lens to freely pan, tilt, and rotate to every angle.

### Specifications

MODEL NUMBER	VP-326		VP-326H	
VIDEO SYSTEM	NTSC	PAL	NTSC	PAL
IMAGE SIGNAL PROCESS	DIGITAL SIGNAL PROCESSING SYSTEM			
NUMBER OF PIXEL	510(H)×492(V)	500(H)×582(V)	768(H)×494(V)	752(H)×582(V)
PICTURE ELEMENTS	APPROXIMATELY 250K	APPROXIMATELY 290K	APPROXIMATELY 380K	APPROXIMATELY 440K
HORIZONTAL RESOLUTION	MAX:420 TVL		MAX:520 TVL	
POWER SUPPLY	12VDC			
POWER CONSUMPTION	200MA			
SYNCHRONIZATION	INTERNAL			
SCANNING SYSTEM	2:1 INTERLACE			
S/N RATIO	48 dB			
SENSITIVITY	0.01 LUX @ F1.4			
AUTO GAIN CONTROL	AUTO			
WHITE BALANCE	AUTO			
ELECTRONIC SHUTTER	OFF: 1/60S AUTO: 1/60S TO 1/10000S	OFF: 1/50S AUTO: 1/50S TO 1/10000S	OFF: 1/60S AUTO: 1/60S TO 1/10000S	OFF: 1/50S AUTO: 1/50S TO 1/10000S
OUTPUT	1VP-P COMPOSITE VIDEO OUTPUT, 75OHMS			
OPERATION TEMPERATURE	-5°C ~ 60°C / LESS THAN 70%			
LENS MOUNT	3.6MM			
DIMENSIONS (W x H x D)	Ø 92MM X 74MM			
WEIGHT	430 G			